

Isoplex MFM-FLOW Gas Mass Flow Meter

Isoplex MFM-FLOW series features a closed-loop control system that integrates a high-precision mass flow sensor, a laminar flow element, an electromagnetic control valve and a precision amplification circuit. At its core lies the principle of calorimetry based on the temperature difference across a capillary tube; by measuring changes in the distribution of heat conduction caused by the flow of the fluid, it enables direct detection of the mass flow rate of the gas. This series not only delivers highly accurate flow measurement but also utilises an internal closed-loop control system to automatically actuate the control valve, ensuring that the actual flow rate strictly matches the setpoint signal.

Core Operating Principle

- **Thermal Sensing:** As the fluid flows through the measuring capillary, it carries away heat from the upstream side of the sensor and transfers it downstream.
- **Signal Processing:** The sensor detects the temperature difference between the upstream and downstream sides of the capillary, and this signal is precisely amplified by a multi-layer circuit board.
- **Closed-Loop Control:** The control circuit continuously compares the sensor signal with a preset target value in real time, and uses the difference to drive the control valve, dynamically compensating for flow fluctuations.

Technical Features & Advantages

- **Thermal Mass Flow Principle**
The measurement results directly reflect the number of gas molecules. The measurement process requires no temperature or pressure compensation, effectively eliminating interference from environmental fluctuations on control accuracy.
- **Structural Stability**
The flow divider features a laminar flow stack design. Compared to traditional structures, the laminar flow stack provides a more stable flow field distribution, ensuring excellent linearity and long-term operational reliability across a wide measurement range.
- **Excellent Performance at Ultra-Low Flow Rates**
Thanks to the high-sensitivity sensor design, this product features short warm-up times and minimal zero-point drift. Even during ultra-low flow control tasks, it maintains extremely high setpoint repeatability and measurement accuracy.
- **High-Immunity Electronic System**
The circuit board employs a multi-layer routing process. This design not only reduces the device's size but also significantly enhances the circuit's electromagnetic compatibility and immunity to interference, ensuring signal purity even in complex industrial electromagnetic environments.

Application Area

Semiconductor processes, laboratory analysis, fuel cell R&D, environmental monitoring, and precision vacuum coating.

Visual Identification

To help users easily distinguish between different gases, we have designed three color schemes, which can also be customized to meet specific requirements.

Red: Toxic and hazardous gases, such as hydrogen sulfide and ammonia

Yellow: Flammable and explosive gases, such as hydrogen and oxygen

Gray: Inert gases, such as air and nitrogen

Model Selection

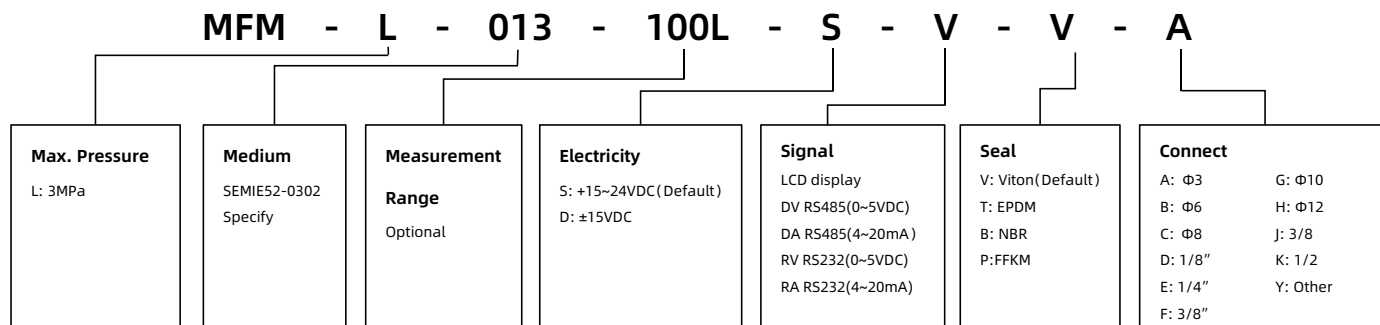

Specification of Isoplex MFM-FLOWGas Mass Flow Meter

	Low Range		Medium Range			Large Range
	Analog	Local Display	Local Display	Digital	Analog	Local Display
Range	5~500 mL _v /min, 1~30 L _v /min (Air)		30~300slm (Air)			300~3000slm (Air)
Accuracy	±1.0%F.S (Flow≤10 slm) ±1.5%F.S (10 slm < Flow≤ 30 slm)	±1.0%S.P (Flow≥35%F.S) ±0.5%F.S (Flow < 35%F.S)	±1.0%S.P (Flow≥35%F.S) ± 0.5%F.S (Flow < 35%F.S)	±1.0%S.P (Flow≥35%F.S) ± 0.5%F.S (Flow < 35%F.S)	±1.0% F.S	±1.0%S.P (Flow≥35%F.S) ± 0.5%F.S (Flow < 35%F.S)
Control Range	Flow Controller: 50:1, Flow Meter: 100:1		Flow Controller: 50:1			Flow Controller: 50:1
Repeatability	±0.2%F.S	±0.2%F.S	±0.2%F.S	±0.2% F.S	±0.2% F.S	±0.2%F.S
Linearity	±0.5%F.S (Flow≤10 slm) , ±1.0%F.S (10 slm < Flow≤ 30 slm)	±0.5%F.S	±0.5%F.S	±0.5% F.S	±0.5% F.S	±0.5%F.S
Temperature sensitivity	-	zero: < ± 0.05% FS/°C span: < ± 0.1% F.S/°C	zero: < ± 0.05% FS/°C span: < ± 0.1% F.S/°C	zero: < ± 0.05% FS/°C span: < ± 0.1% F.S/°C	zero: < ± 0.05% FS/°C span: < ± 0.1% F.S/°C	zero: < ± 0.05% FS/°C span: < ± 0.1% F.S/°C
Response Time	1~4 sec (T98)	< 2 sec (T98)	1~4sec (T98)	1~4 sec (T98)	1~4 sec (T98)	1~4 sec (T98)
Environmental temperature	5~45°C	5~45°C (Ensure Accuracy : 15~35°C)	5~45°C (Ensure Accuracy : 15~35°C)			5~45°C (Ensure Accuracy : 15~35°C)
Leak integrity, outboard	< 1×10 ⁻⁸ Pa·M ³ /S(He)	< 1×10 ⁻¹⁰ Pa·M ³ /S(He)	< 1×10 ⁻¹⁰ Pa·M ³ /S(He)	< 1×10 ⁻⁹ Pa·M ³ /S(He)	< 1×10 ⁻⁸ Pa·M ³ /S(He)	< 1×10 ⁻¹⁰ Pa·M ³ /S(He)
Warm-up Time	15 min					
Power Supply	15~24 vdc					
Analog Signal	0~5 vdc or 4~20 mA	-	-	-	0~5 vdc or 4~20 mA	-
Input/Output Signal	-	RS485/RS232 (0~5 vdc or 4~20 mA)	RS485/RS232 (0~5vdc or 4~20mA)	RS485/RS232 (0~5vdc or 4~20mA)	-	RS485/RS232 (0~5vdc or 4~20mA)
Primary Wetted Materials	SS316 Stainless Steel					
Max Pressure Rating	3 MPa (Special: 10 MPa)	3 MPa	30bar	30 bar	30 bar	3MPa
Max Operating Pressure	1 MPa					
Pressure difference	0.05 - 0.4 MPa					
Mechanical connection	Standard: Double ferrule connection (Options: Thread VCR VCO or Flange)					
Seals	Viton, NBR, EPDM, Perfluoroethane	-	-	Viton, NBR, EPDM, Perfluoroethane	-	-
Appearance	